

# Electroinduced $S_{RN}1$ preparative reactions

## Part I: Estimation of the limiting diffusion currents on various cathodic materials in liquid ammonia and dimethylformamide

C. COMBELLAS, Y. LU, A. THIEBAULT

Laboratoire de Chimie et Electrochimie des Matériaux Moléculaires, ESPCI, 10, rue Vauquelin, 75231 Paris Cedex 05, France

Received 22 May 1992; revised 21 October 1992

Limiting diffusion currents are estimated by an indirect method which consists in determining the chemical yield of substitution product in the electrosynthesis of a biaryl by an  $S_{RN}1$  type reaction. The limiting diffusion currents can then be deduced from the yields. Different industrial cathodic materials have been investigated both in liquid ammonia ( $-40^{\circ}\text{C}$ ) and dimethylformamide ( $20^{\circ}\text{C}$ ). The limiting diffusion currents are generally about 2.8 times larger in ammonia than in dimethylformamide.

### Nomenclature

$R$	yield in biaryl with respect to the reacted aromatic halide
$k_d$	diffusion rate constant
$k_2$	rate constant of the key-reaction between $\text{Ar}^{\bullet}$ and $\text{Nu}^-$
$A$	cathode area
$D$	diffusion coefficient of the mediator
$D_1$	diffusion coefficient of mediator $P_1$
$D_2$	diffusion coefficient of mediator $P_2$ (in the same medium as for $D_1$ )
$D_{\text{NH}_3}$	diffusion coefficient of the mediator in $\text{NH}_3$
$D_{\text{DMF}}$	diffusion coefficient of the mediator in DMF
$D_{1,\text{NH}_3}$	diffusion coefficient of mediator $P_1$ in $\text{NH}_3$
$D_{2,\text{NH}_3}$	diffusion coefficient of mediator $P_2$ in $\text{NH}_3$
$D_{2,\text{DMF}}$	diffusion coefficient of mediator $P_2$ in DMF
$\delta$	diffusion layer thickness
$\delta_{\text{NH}_3}$	diffusion layer thickness in $\text{NH}_3$
$\delta_{\text{DMF}}$	diffusion layer thickness in DMF
$i_{\text{lim}}$	limiting diffusion current of the mediator
$I_{\text{lim}}$	limiting diffusion current of the mediator per unit of concentration of the mediator
$I_{\text{lim}}$	limiting diffusion current of the mediator per unit of concentration of the mediator and per unit of cathode area
$I_{\text{lim},\text{NH}_3}$	limiting diffusion current of the mediator in $\text{NH}_3$ (normalized with respect to the cathode area and the concentration)
$I_{\text{lim},\text{DMF}}$	limiting diffusion current of the mediator in DMF (normalized with respect to the cathode area and the concentration)
$ip$	reduction peak current of the mediator
$ip_{\text{NH}_3}$	reduction peak current of the mediator in $\text{NH}_3$ (measured by cyclic voltammetry)
$ip_{\text{DMF}}$	reduction peak current of the mediator in DMF (measured by cyclic voltammetry in

$\Psi$	solvent association factor
$M_s$	solvent molecular weight
$\eta$	solvent absolute viscosity
$V$	substrate molecular volume
$V_1$	molecular volume of mediator $P_1$
$V_2$	molecular volume of mediator $P_2$
$\omega$	rotation speed of the electrode
$\nu$	kinematic viscosity, $\nu = \eta/d$
$d$	solvent density
$\frac{\text{ArH}}{\text{ArNu}}$	amount of reduction product, mol
$\frac{\text{ArNu}}{\text{ArNu}}$	amount of coupling product, mol

the same conditions of concentration, cathode and scan speed as in  $\text{NH}_3$ )

### 1. Introduction

$S_{RN}1$  reactions are a powerful synthetic tool when induced in liquid ammonia. Such reactions allow the coupling of a  $\sigma$ -aryl radical  $\text{Ar}^{\bullet}$  and a nucleophile  $\text{Nu}^-$  to obtain a new link such as C-C, C-P, C-S, C-Se, etc [1, 2]. The reaction is summarized by the electrocatalytic cycle represented in Scheme 1. At the laboratory scale, the inducement of the reaction can be achieved by photochemical or electrochemical means. The first means is the most frequently used because it is easy to perform. Nevertheless, since the amount and distribution of energy supplied to the

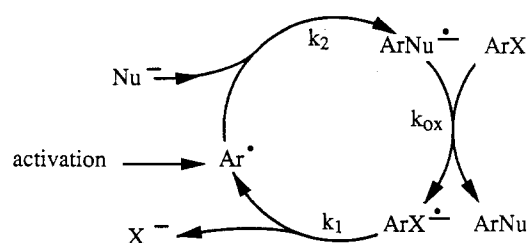
Scheme 1. Electrocatalytic  $S_{RN}1$  cycle.

system are difficult to control, the induction itself is badly controlled. In contrast to the previous means, electrochemical inducement is easy to control [3]. Under galvanostatic conditions [3–5] it can also be easily quantified by the electrolysis intensity; limiting diffusion currents have therefore to be known for the cathodic material used. At present, this induction method is barely used at a preparative scale because of chemical engineering problems. The situation may change in the future because of the development of sacrificial anode techniques [6–8] which make possible simplification of experimental cells. Single-compartment electrolytic cells without separators may be used.

Liquid ammonia is the best solvent for the reaction because it does not transfer hydrogen atoms, which is not the case for organic solvents. Secondary reactions, which decrease the selectivity and yield of the substitution reaction, are therefore avoided in this solvent.

However, the importance of hydrogen atom transfer reactions is not the main criterion for the choice of the reaction solvent. Acetonitrile, dimethylformamide and dimethylsulphoxide have also been described as convenient solvents [9–14]. Recently [15] kinetic studies in pure liquid ammonia and in mixtures of ammonia and organic solvents have shown that hydrogen atom transfer rate constants of organic solvents to aryl radicals are about 100 to 1000 times slower than coupling reaction rate constants. Some organic solvents are therefore suitable as replacements for liquid ammonia in  $S_{RN}1$  reactions, which is interesting from the point of view of chemical engineering. Among these solvents, dimethylformamide (DMF) is attractive since it is about 10 times inferior as a hydrogen atom donor than acetonitrile and dimethylsulphoxide.

To compare the capabilities of liquid ammonia and dimethylformamide in large scale  $S_{RN}1$  reactions, the limiting diffusion currents of two standard compounds were measured on different cathodic materials in the two solvents. These two compounds were 4,4'-bipyridyl and 1,2-dicyanobenzene, which are often used as redox mediators under  $S_{RN}1$  conditions. The cathodic materials were gold, platinum, stainless steel, nickel and aluminium, which are commonly used either for laboratory or industrial purposes.

## 2. Theory

The measurement of the limiting diffusion current  $i_{lim}$  of a reducible species P involved in a monoelectronic reversible system can easily be achieved by classical voltamperometric techniques if both the concentration of the species and the surface of the electrode are not too large. But if one among these two factors is high, these techniques cannot be used because of the large current intensities and of the continuous change in the bulk concentration of P.

Here an indirect method of measurement is proposed consisting of performing an  $S_{RN}1$  reaction in the presence of a redox mediator P. The yield,  $R$ , in substitution product depends on the limiting diffusion

current [5]. The chosen  $S_{RN}1$  reaction must not be too efficient ( $R$  large irrespective of the cathode) or too inefficient ( $R$  small in all cases). Therefore the reaction between 4-chlorobenzonitrile and 2,6-di-*tert*-butylphenoxide has been chosen as a model reaction since the rate constant of the  $S_{RN}1$  key reaction is moderate:

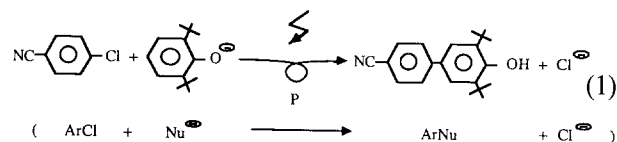

The  $S_{RN}1$  reaction is induced by  $P^\cdot$  which reduces 4-chlorobenzonitrile (ArX) slowly to its anion radical  $\text{ArX}^\cdot$ :

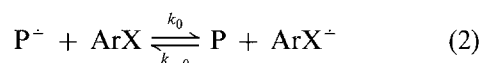

where  $k_{-0} = k_d$ ;  $k_0 < k_d$ ;  $k_d$  = diffusion rate constant.

In liquid ammonia and dimethylformamide, the main secondary reaction produces  $\text{Ar}^-$  by reduction of  $\text{Ar}^\cdot$  by  $P^\cdot$ :

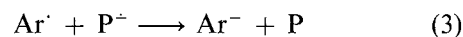

In pure liquid ammonia, when the reaction is performed in a single-compartment cell by imposing a constant current intensity,  $i$ , between a platinum grid cathode and a magnesium sacrificial anode, the chemical yield in ArNu can be related to the limiting diffusion current of the mediator P by the following relation [5]:

$$R = \frac{1}{1 + \frac{0.63k_d[P]i}{k_2[\text{Nu}^-]i_{lim}}} \quad (4)$$

For this relation to be valid, redox catalysis must not be too efficient,  $P^\cdot$  has to be consumed inside the diffusion layer and  $i$  must be lower than  $i_{lim}$ . The two first conditions imply that  $k_0$  is lower than about  $20000 \text{ M}^{-1} \text{ s}^{-1}$  and higher than about  $20 \text{ M}^{-1} \text{ s}^{-1}$ . In forced convection,  $i_{lim}$  depends on the cathode dimensions, the diffusion coefficient of P in the medium, the diffusion layer thickness and the concentration of P, according to [16]:

$$i_{lim} = \frac{FAD}{\delta} [P] \quad (5)$$

The ratio  $i_{lim}/[P]$  does not therefore depend on the concentration of the mediator. We call this  $I_{lim}$ . It represents the limiting diffusion current of the mediator per unit of concentration of the mediator:

$$I_{lim} = \frac{i_{lim}}{[P]}$$

Relation 4 can be written as a function of  $I_{lim}$  by:

$$R = \frac{1}{1 + \frac{0.63 k_d i}{k_2 [\text{Nu}^-] I_{lim}}} \quad (6)$$

We have extended the range of application of

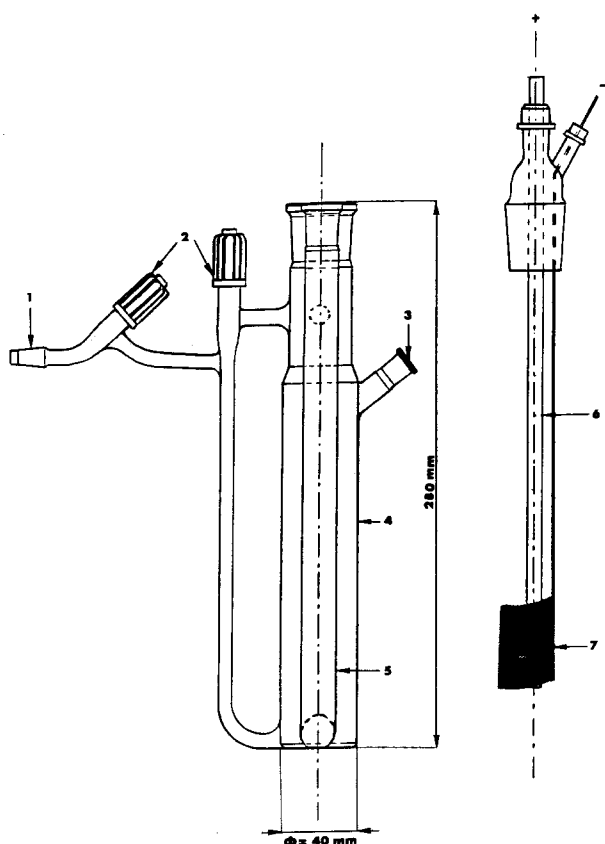

Fig. 1. Scheme of the electrolytic device: (1) nitrogen inlet, (2) vacuum stopcocks with PTFE keys, (3) reactants entry, (4) main compartment, (5) reference compartment, (6) magnesium rod anode, (7) cathode.

Relation 6 to dimethylformamide, which is a bad hydrogen atom donor solvent and different cathodic materials. From the value of  $R$ , it is easy to deduce  $I_{lim}$  for the given cathodic material:

$$I_{lim} = \frac{0.63k_d i}{k_2[\text{Nu}^-](1/R - 1)} \quad (7)$$

### 3. Experimental results

#### 3.1. Electrolytic device

The electrolytic device shown in Fig. 1 was a glass cell equipped with four entries corresponding to: (i) auxiliary and working electrodes. A sacrificial anode (auxiliary electrode) which was a magnesium rod was surrounded by a cylindrical shaped cathode (working electrode). The distance between the two electrodes was about 1 cm; (ii) a separate reference compartment. The reference system ( $\text{Ag}/\text{Ag}^+$ ,  $[\text{Ag}^+] = 10^{-1} \text{ M}$ ) [17] is only used for kinetics determinations by cyclic voltammetry; (iii) the introduction of the reactants; and (iv) a nitrogen inlet.

The solution was stirred with a magnetic stirrer. When ammonia was the solvent, the temperature of the solution was maintained at  $-40^\circ \text{ C}$  by a cryocooler (Huber, Bioblock Scientific). With DMF, the experiments were carried out at room temperature.

#### 3.2. Cathodic materials

The characteristics of the investigated cathodic materials are reported in Table 1.

#### 3.3. Chemicals and apparatus

All the chemicals (electrolytes, substrates) were commercially available and used without further purification. Ammonia was condensed at low pressure ( $p = 10^{-2} \text{ mm Hg}$ ) using a vacuum line. DMF was distilled over calcium hydride in an inert atmosphere under reduced pressure (5 mm Hg) before use.

The electrolyses were performed using a stabilized power supply (EDL, 20 V, 1.2 A, Sodilec). Coulometric measurements were carried out with an integrator (IG5-N, Tacussel). Titration of the products was performed with a gas chromatograph (GC 121 DFL, Delsi Instruments) equipped with a dimethylsiloxane column.

#### 3.4. Experimental procedure

The electrolyses were carried out in standard experimental conditions using about 80 mL of solvent. The electrolytes were potassium bromide (4 g, 34 mmol) with liquid ammonia and tetrabutylammonium tetrafluoroborate (2 g, 6 mmol) in DMF. The nucleophile was prepared *in situ* by deprotonation of 2,6-di-*tert*-butylphenol by potassium-*tert*-butoxide. In liquid ammonia, the mediator was 4,4'-bipyridyl and in DMF, it was 1,2-dicyanobenzene. With 4,4'-bipyridyl as the mediator, potassium hydroxide was added to the medium to avoid the protonation of  $\text{P}^+$ . It was prepared *in situ* by deprotonation of water by potassium-*tert*-butoxide. The electrolyte, 2,6-di-*tert*-butylphenol ( $n$  mmol,  $8 < n < 16$ ), water ( $\approx 3$  mmol), potassium-*tert*-butoxide ( $\approx n + 3$  mmol), 4-chlorobenzonitrile ( $\approx 3$  mmol) and the mediator ( $\approx 2$  mmol) were successively introduced into the cell. The electrolysis was performed by setting a constant current between the electrodes.

When the electrolysis was over, the solution was neutralized by 20 mmol of ammonium bromide and the ammonia was evaporated. The reaction products were extracted from the solid residue by dichloromethane. The amounts of unreacted chloro-4-benzonitrile and biphenyl were determined by gas chromatography.

### 4. Results and discussion

#### 4.1. Determination of the different values of $I_{lim}$

The reduction of 4-chlorobenzonitrile ( $\text{ArX}$ ) can be performed indirectly by different mediators (P) among which 1,2-dicyanobenzene and 4,4'-bipyridyl have been chosen for this study. The characteristic rate constants implied in the two solvents are reported in Table 2. Since two conditions on the value of  $k_0$  have to be fulfilled for Relations 4 and 7 to be valid, we can

Table 1. Characteristics of the cathodic materials

Cathodic material	Specification	10 <sup>4</sup> Area/m <sup>2</sup>	Origin
Platinum grid	256 × 10 <sup>4</sup> mesh m <sup>-2</sup>	3.3	Comptoir Lyon Allemand
Platinum grid	1024 × 10 <sup>4</sup> mesh m <sup>-2</sup>	9	Comptoir Lyon Allemand
Platinum exmet	1024 × 10 <sup>4</sup> mesh m <sup>-2</sup>	7.5	Le Métal Déployé
Gold grid	144 × 10 <sup>4</sup> mesh m <sup>-2</sup>	7.5	Le Métal Déployé
Stainless steel grid	156 × 10 <sup>4</sup> mesh m <sup>-2</sup>	9.1	Le Métal Déployé
Stainless steel grid	324 × 10 <sup>4</sup> mesh m <sup>-2</sup>	18.5	Le Métal Déployé
Aluminium exmet	18 × 10 <sup>4</sup> mesh m <sup>-2</sup>	10	Le Métal Déployé
Gold plated nickel foam	FN60; 100 g Au m <sup>-2</sup>	9	Sorapec
Nickel foam	MN 020 0500 050*	13.5	Sorapec
Nickel foam	MN 045 0200 050†	12.5	Sorapec
Nickel foam	MN 060 0200 050‡	16	Sorapec
Nickel felt	FN 90§	9	Sorapec

\*800 pores m<sup>-1</sup>, 1800 m<sup>2</sup> m<sup>-3</sup>†1800 pores m<sup>-1</sup>, 4000 m<sup>2</sup> m<sup>-3</sup>‡2400 pores m<sup>-1</sup>, 5500 m<sup>2</sup> m<sup>-3</sup>§24 000 m<sup>2</sup> m<sup>-3</sup>

deduce from the values of Table 2 that 4,4'-bipyridyl is a suitable mediator in liquid ammonia whilst 1,2-dicyanobenzene is suitable in DMF.

The results obtained in the two solvents are reported in Table 3 (NH<sub>3</sub>, -40°C) and Table 4 (DMF, 20°C).

#### 4.2. Determination of the normalized currents $I_{lim}$

In order to compare the performances of the different cathodic materials in the two solvents, we have first normalized the limiting diffusion currents with respect to the surface of the cathode A:

$$I_{lim} = \frac{I_{lim}}{A} \quad (8)$$

Secondly, we have normalized them with respect to the nature of the mediator, since the diffusion coefficients of 4,4'-bipyridyl ( $D_1$ ) and 1,2-dicyanobenzene ( $D_2$ ) in the same solvent are slightly different. The ratio  $D_1/D_2$  has been calculated by an electrochemical method and a structural one.

The first method consisted in measuring, by cyclic voltammetry at 0.2 V s<sup>-1</sup>, the reduction intensities of 4,4'-bipyridyl ( $ip_1$ ) and 1,2-dicyanobenzene ( $ip_2$ ) in liquid ammonia at -40°C, since the reduction peak current of a Nernstian monoelectronic system P/P<sup>-</sup> in cyclic voltammetry (sweep rate,  $v$ ) is given by [16]:

$$ip = 0.446FA[P]D^{0.5} \left( \frac{Fv}{RT} \right)^{0.5} \quad (9)$$

Table 2. Kinetic rate constants of the system

Solvent	NH <sub>3</sub> at -40°C	DMF at 20°C
$k_{diff}/M^{-1} s^{-1}$ *		3 × 10 <sup>10</sup> [4]
$k_0/M^{-1} s^{-1}$ †	$\begin{cases} P = 1,2\text{-dicyanobenzene} \\ P = 4,4'\text{-bipyridyl} \end{cases}$	10 <sup>10</sup> [18]
		40 [18]
$k_2/M^{-1} s^{-1}$ ‡		10 <sup>5</sup> §
		8.10 <sup>8</sup> #
		5.2 × 10 <sup>3</sup> §
		4 × 10 <sup>9</sup> [5]

\*diffusion rate constant

†homogeneous electron transfer rate constant between 4-chlorobenzonitrile and P

‡coupling rate constant between Ar<sup>+</sup> and Nu<sup>-</sup> (measured by perturbed redox catalysis)

§calculated from the standard potentials values

#this work; measured according to the method described in [19]

The ratio  $D_{1,NH_3}/D_{2,NH_3}$  was therefore given by:

$$\frac{D_{1,NH_3}}{D_{2,NH_3}} = \left( \frac{ip_1 [P_2]}{ip_2 [P_1]} \right)^2 \quad (10)$$

The second method consisted in estimating the ratio of the molecular volumes  $V_1$  and  $V_2$  of the two molecules. The molecular volume was estimated by plunging a molecular model of each molecule into water and by measuring the increase of volume of the liquid. According to Wilke and Chang's relation, the diffusion coefficient  $D$  of a substrate is given by [20]:

$$D = 7.4 \times 10^{-15} T(\Psi M_s)^{0.5} \eta^{-1} V^{-0.6} \quad (11)$$

The ratio  $D_{1,NH_3}/D_{2,NH_3}$  can therefore be expressed by:

$$\frac{D_{1,NH_3}}{D_{2,NH_3}} = \left( \frac{V_2}{V_1} \right)^{0.6} \quad (12)$$

The value obtained with the first method was 0.90 whilst it was 0.88 with the second one. In the following, we have taken an average of 0.89 and extrapolated the values obtained in liquid ammonia with 4,4'-bipyridyl to 1,2-dicyanobenzene. The values of the normalized currents in NH<sub>3</sub> at -40°C ( $I_{lim,NH_3}$ ) and in DMF ( $I_{lim,DMF}$ ) at +20°C are reported in Table 5.

#### 4.3. Comparison of the different cathodic materials

All the values obtained in liquid ammonia were high.

Table 3. Experimental conditions and results of the electrolyses performed in liquid ammonia at  $-40^{\circ}\text{C}$ 

Cathodic material	Specification	$10^3 V/\text{dm}^3(\text{a})$	$Nu^-/\text{m mol}(\text{b})$	$ArX_0/\text{m mol}(\text{c})$	$i/\text{mA}(\text{d})$	$ArX_e/\text{m mol}(\text{e})$	$ArNu/\text{g}(\text{f})$	$R/\%(\text{g})$	$I_{lim}/\text{A M}^{-1}(\text{h})$
Platinum grid	$256 \times 10^4 \text{ mesh m}^{-2}$	85	10.8	3.09	50	0	0.751	79	8.0
Platinum grid	$1024 \times 10^4 \text{ mesh m}^{-2}$	70	10.2	2.91	50	0.034	2.47	86	11
Platinum exmet	$1024 \times 10^4 \text{ mesh m}^{-2}$	65	8.52	2.32	50	0.013	1.78	78	7.1
Gold grid	$144 \times 10^4 \text{ mesh m}^{-2}$	90	11.9	3.00	50	0.020	0.772	84	11
Stainless steel grid	$156 \times 10^4 \text{ mesh m}^{-2}$	83	11.1	2.75	100	0.040	1.92	71	10
Stainless steel grid	$324 \times 10^4 \text{ mesh m}^{-2}$	80	14.8	3.05	100	0	2.59	85	16
Aluminium exmet	$18 \times 10^4 \text{ mesh m}^{-2}$	80	11.8	2.93	30	0.147	1.92	69	2.6
Gold plated nickel foam	FN60; 100 g Au $\text{m}^{-2}$	83	12.6	2.91	100	0.03	2.53	88	26
Nickel foam	MN 020.0500.050	80	12.6	2.93	30	0.04	2.35	81	4.2
Nickel foam	MN 045.0200.050	80	15.2	2.95	50	0	2.28	77	4.8
Nickel foam	MN 060.0200.050	80	15.5	3.05	50	0.030	2.45	81	6.0
Nickel felt	FN 90	85	12.7	2.89	50	0.039	2.45	86	11

<sup>a</sup> volume of liquid ammonia<sup>b</sup> amount of 2,6-di-*tert*-butylphenoxide<sup>c</sup> amount of started aromatic halide<sup>d</sup> electrolysis current intensity<sup>e</sup> amount of unreacted aromatic halide<sup>f</sup> amount of 4-cyano-3',5'-di-*tert*-butyl-4'-hydroxy-1,1'-biphenyl<sup>g</sup> chemical yield in ArNu with respect to the reacted aromatic halide<sup>h</sup> limiting diffusion current of the mediator on the cathode;  $I_{lim} = 0.63 k_d i/k_2 [Nu^-] [1/R - 1]$ 

amount of mediator (4,4'-bipyridyl): 2 m mol; electric charge passed through the circuit = 250 C (0.85 Faraday per mole of starting aromatic halide)

Table 4. Experimental conditions and results of the electrolyses performed in DMF at room temperature

Cathodic material	Specification	$Nu^- / \text{m mol}^b$	$ArX_0 / \text{m mol}^c$	$ArX_t / \text{m mol}^e$	$ArNu / \text{m mol}^f$	$R / \%$ <sup>g</sup>	$I_{lim} / \text{A M}^{-1h}$
Platinum grid	$1024 \times 10^4 \text{ mesh m}^{-2}$	15.1	2.94	0.98	1.32	68	4.5
Platinum exmet	$1024 \times 10^4 \text{ mesh m}^{-2}$	15.0	2.90	0.18	1.67	62	2.9
Gold grid	$144 \times 10^4 \text{ mesh m}^{-2}$	15.1	2.97	1.5	0.92	64	3.8
Stainless steel grid	$324 \times 10^4 \text{ mesh m}^{-2}$	15.0	2.79	0.48	1.49	65	7.7
Gold plated nickel foam	FN60	15.9	2.83	0.40	1.57	65	5.6
Nickel foam	MN 020 0500 050	15.1	3.10	0	1.87	60	2.5
Nickel felt	FN90	15.1	2.65	0.48	1.31	60	3.3

(b),(c),(e),(f),(g),(h): same as in Table 3

Volume of solution =  $80 \times 10^{-3} \text{ dm}^3$ ; electrolysis current intensity = 50 mA; amount of mediator (1,2-dicyanobenzene): 2 m mol; electric charge passed through the circuit = 350 C (1.2 Faraday per mole of starting aromatic halide)

The aluminium exmet was the least interesting material ( $I_{lim, \text{NH}_3} \approx 3000 \text{ A M}^{-1} \text{ m}^{-2}$ ), whilst the gold plated nickel foam was the best one ( $I_{lim, \text{NH}_3} \approx 30000 \text{ A M}^{-1} \text{ m}^{-2}$ ). In the case of platinum grids, the limiting diffusion current decreased when the number of meshes per surface unit of the cathode increased. The three nickel foams gave about the same results ( $I_{lim, \text{NH}_3} \approx 4000 \text{ A M}^{-1} \text{ m}^{-2}$ ) although their number of pores per unit length and their specific areas were different. Limiting diffusion currents were largely higher with the nickel felt than with the different foams. The difference between these two types of materials was higher in  $\text{NH}_3$  than in DMF. A difference of nearly one order of magnitude was observed between the gold plated nickel foam and the three other nickel foams.

In DMF, the performance of the gold plated nickel foam was largely smaller than in  $\text{NH}_3$ ; this could be due to differences in the wettability of the material in the two solvents. Such a difference was not observed, either with the other nickel foams, nor with the other cathodic materials in general.

In the two solvents, the limiting diffusion currents obtained with platinum, gold and stainless steel grids were of the same order of magnitude. Since stainless steel grids offer the advantages of cheap cost and good mechanical properties, these materials are particularly interesting.

#### 4.4. Comparison of limiting diffusion currents in $\text{NH}_3$ ( $-40^\circ \text{C}$ ) and DMF ( $+20^\circ \text{C}$ )

From the values obtained in the sixth column of Table 5, it may be deduced that, except in the case of the golden nickel foam, the limiting diffusion currents were, on average, about 2.8 times larger in  $\text{NH}_3$  ( $-40^\circ \text{C}$ ) than in DMF ( $20^\circ \text{C}$ ):

$$\frac{I_{lim, \text{NH}_3}}{I_{lim, \text{DMF}}} \approx 2.8$$

In order to evaluate the validity of the present method we have tried to deduce the ratio of the limiting diffusion currents in ammonia ( $I_{lim, \text{NH}_3}$ ) and DMF ( $I_{lim, \text{DMF}}$ ) from cyclic voltammetry and literature data. This can be estimated using Relation 5 by:

$$\frac{I_{lim, \text{NH}_3}}{I_{lim, \text{DMF}}} = \frac{D_{\text{NH}_3} \delta_{\text{DMF}}}{D_{\text{DMF}} \delta_{\text{NH}_3}} \quad (13)$$

The ratio  $\delta_{\text{DMF}} / \delta_{\text{NH}_3}$  of the diffusion layer thicknesses can be estimated using the expression for the diffusion layer thickness at the rotating disc electrode [16]:

$$\delta = 1.61 D^{1/3} \omega^{1/2} \nu^{1/6} \quad (14)$$

The following expression ensues:

$$\frac{\delta_{\text{DMF}}}{\delta_{\text{NH}_3}} = \left( \frac{D_{\text{DMF}}}{D_{\text{NH}_3}} \right)^{1/3} \left( \frac{\nu_{\text{DMF}}}{\nu_{\text{NH}_3}} \right)^{1/6}$$

Table 5. Normalized limiting diffusion currents in liquid ammonia at  $-40^\circ \text{C}$  and dimethylformamide at room temperature

Cathodic material	Specification	$I_{lim} / \text{A M}^{-1} \text{ m}^{-2}$			
		$\text{NH}_3 (-40^\circ \text{C})$		$\text{DMF } (20^\circ \text{C})$	
		4,4'-bipyridyl	1,2-dicyanobenzene ( $I_{lim, \text{NH}_3}$ )	1,2-dicyanobenzene ( $I_{lim, \text{DMF}}$ )	$\frac{I_{lim, \text{NH}_3}}{I_{lim, \text{DMF}}}$
Platinum grid	$256 \times 10^4 \text{ mesh m}^{-2}$	24 500	27 500	—	—
Platinum grid	$1024 \times 10^4 \text{ mesh m}^{-2}$	12 500	14 000	5050	2.8
Platinum exmet	$1024 \times 10^4 \text{ mesh m}^{-2}$	9 500	11 000	3850	2.9
Gold grid	$144 \times 10^4 \text{ mesh m}^{-2}$	14 000	16 000	5100	3.1
Stainless steel grid	$156 \times 10^4 \text{ mesh m}^{-2}$	11 000	12 000	—	—
Stainless steel grid	$324 \times 10^4 \text{ mesh m}^{-2}$	10 000	11 000	4150	2.7
Aluminium exmet	$18 \times 10^4 \text{ mesh m}^{-2}$	2 500	2 800	—	—
Gold plated nickel foam	FN60; 100 g $\text{Au m}^{-2}$	29 000	32 500	4150	7.8
Nickel foam	MN 020 0500 050	3 750	4 200	1850	2.3
Nickel foam	MN 045 0200 050	3 800	4 250	—	—
Nickel foam	MN 060 0200 050	3 100	3 500	—	—
Nickel felt	FN90	11 000	12 500	3650	3.4

The ratio  $I_{\text{lim,NH}_3}/I_{\text{lim,DMF}}$  can therefore be estimated by:

$$\frac{I_{\text{lim,NH}_3}}{I_{\text{lim,DMF}}} = \left(\frac{D_{\text{NH}_3}}{D_{\text{DMF}}}\right)^{2/3} \left(\frac{v_{\text{DMF}}}{v_{\text{NH}_3}}\right)^{1/6} \quad (15)$$

$D_{\text{NH}_3}/D_{\text{DMF}}$  was deduced by cyclic voltammetry from the ratio of the reduction peak intensities of 1,2-dicyanobenzene in the two media using Relation 9, provided the same concentrations, cathodes and scan speeds were used:

$$\frac{i_{\text{pNH}_3}}{i_{\text{pDMF}}} = \left(\frac{D_{2,\text{NH}_3}}{D_{2,\text{DMF}}}\right)^{0.5} \quad (16)$$

The experiments were performed with a gold disc as the cathode (diameter: 0.5 mm) using different concentrations of 1,2-dicyanobenzene and the following average value was obtained:

$$\frac{D_{2,\text{NH}_3}}{D_{2,\text{DMF}}} = 3.13$$

$v_{\text{DMF}}/v_{\text{NH}_3}$  was obtained from literature data (at  $-40^\circ\text{C}$ ,  $\eta_{\text{NH}_3} = 0.27 \times 10^{-3} \text{ p}$ ,  $d_{\text{NH}_3} = 0.685$  [21], at  $+20^\circ\text{C}$ ,  $\eta_{\text{DMF}} = 0.92 \times 10^{-3} \text{ p}$ ,  $d_{\text{DMF}} = 0.94$  [22]):

$$\frac{v_{\text{DMF}}}{v_{\text{NH}_3}} = 2.5.$$

At the rotating disc electrode, the ratio of the normalized limiting diffusion currents were therefore calculated using Relation 15:

$$\frac{I_{\text{lim,NH}_3}}{I_{\text{lim,DMF}}} \approx 2.5$$

This value was close to that obtained from Table 5 ( $I_{\text{lim,NH}_3}/I_{\text{lim,DMF}} \approx 2.8$ ), which demonstrated the validity of the method of measurement of limiting diffusion currents.

#### 4.5. Conclusions and prospects

As the experimental ratios of the limiting diffusion currents in liquid ammonia ( $-40^\circ$ ) and dimethylformamide ( $20^\circ$ ) are close to those obtained directly by cyclic voltammetry measurements, the values of the limiting diffusion currents in any organic solvent can be estimated from that obtained in liquid ammonia by cyclic voltammetry using Relations 15 and 16.

From a preparative point of view, in electroinduced  $S_{RN}1$  reactions, in the absence of hydrogen atom transfer, the electric charge ( $it$ ) passed through the circuit is consumed in the reduction of  $\text{ArCl}$  to  $\text{ArH}$ :

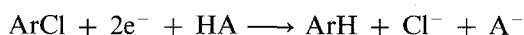

(HA: acidic impurity in the solvent, or the solvent itself).

The amount of reduction product,  $\text{ArH}$ , is therefore given by:

$$\text{ArH} = it/2F \quad (17)$$

The amount of coupling product  $\text{ArNu}$  can be calculated under galvanostatic conditions, using Relations

6 and 16:

$$\text{ArNu} = \frac{k_2[\text{Nu}^-]I_{\text{lim}}}{0.63k_d2F} t \quad (18)$$

$\text{ArNu}$  depends on the ratio  $k_2[\text{Nu}^-]/k_d$  and on  $I_{\text{lim}}$ . In this study, this ratio is about 1.7 times larger in  $\text{NH}_3$  than in DMF, whilst  $I_{\text{lim}}$  is about 2.5 to 2.8 times larger in  $\text{NH}_3$  than in DMF. Consequently, in a given electrolytic device, the productivity of  $\text{ArNu}$  will be 4 to 5 times larger with  $\text{NH}_3$  as the solvent than with DMF, or, for a given productivity, the size of the electrolytic device will have to be 4 to 5 times larger with DMF than with  $\text{NH}_3$ .

Therefore, for large scale production,  $\text{NH}_3$  is more interesting than DMF, whilst at the laboratory scale, the choice of the solvent is not the main factor, and DMF is an interesting alternative for  $S_{RN}1$  reactions.

#### Acknowledgements

This work was financially supported by Electricité de France and Société Nationale des Poudres et Explosifs, who are gratefully acknowledged. Particular thanks are due to C. Bailleux, J. Chaussard and Y. Robin.

#### References

- [1] J. F. Bunnett, *Acc. Chem. Res.* **11** (1978) 413.
- [2] R. A. Rossi and R. H. de Rossi, in 'Aromatic Nucleophilic Substitution by the  $S_{RN}1$  Mechanism', ACS Monograph 178, American Chemical Society, Washington (1983).
- [3] J. M. Savéant, *Acc. Chem. Res.* **13** (1980) 323.
- [4] C. Amatore, J. Pinson, J. M. Savéant and A. Thiébaud, *J. Electroanal. Chem.* **128** (1981) 231.
- [5] N. Alam, C. Amatore, C. Combéllas, A. Thiébaud and J. N. Verpeaux, *J. Org. Chem.* **55** (1990) 6347.
- [6] J. Chaussard, J. C. Folest, J. Y. Nedelec, J. Périchon, S. Sibille, M. Troupel, *Synthesis* (1990) 369.
- [7] C. Combéllas, H. Marzouk, A. Thiébaud, *J. Appl. Electrochem.* **21** (1991) 267.
- [8] A. Savall, *Actualité Chimique* **1** (1992) 35.
- [9] C. Amatore, J. Pinson, J. M. Savéant and A. Thiébaud, *J. Am. Chem. Soc.* **104** (1982) 1979.
- [10] N. Alam, C. Amatore, C. Combéllas, J. Pinson, J. M. Savéant, A. Thiébaud and J. N. Verpeaux, *J. Org. Chem.* **53** (1988) 1496.
- [11] M. Medebielle, J. Pinson and J. M. Savéant, *J. Am. Chem. Soc.* **56** (1991) 6872.
- [12] C. Degrand, *Tetrahedron* **46** (1990) 5237.
- [13] C. Thobie-Gautier, M. Genesty, C. Degrand, *J. Org. Chem.* **56** (1991) 3452.
- [14] C. Thobie-Gautier, C. Degrand, *ibid.* **56** (1991) 5703.
- [15] C. Combéllas, Y. Lu, A. Thiébaud, EuChem Conference on Electrochemistry, Wiesbaden (21–25 April 1992).
- [16] A. J. Bard, L. R. Faulkner, in 'Electrochemical Methods', Wiley, New York (1980).
- [17] M. Herlem, *Bull. Soc. Chim. Fr.* (1967) 1687.
- [18] C. P. Andrieux, J. M. Savéant and D. Zann, *Nouv. J. Chim.* **8** (1984) 107.
- [19] C. Amatore, M. A. Oturan, J. Pinson, J. M. Savéant, A. Thiébaud, *J. Am. Chem. Soc.* **107** (1985) 3451.
- [20] C. R. Wilke, P. Chang, *Am. Inst. Chem. Eng. J.* **1** (1955) 264.
- [21] J. J. Lagowski, G. A. Moczygemba, in 'The Chemistry of Non-aqueous Solvents', Part II, Acidic and Basic Solvents, Academic Press, New York (1967).
- [22] Riddick, Bunger, in 'Techniques of Chemistry', 2: 'Organic Solvents, Physical Properties and Methods of Purification', 3rd edn., Wiley Interscience, New York (1972) p. 446.